

NOTES:

- ① Numerazione cavita' contatto
Cavity contact numbering
- ② Marchio FCI
FCI trademark
- ③ Sigla identificazione materiale
Material identification
- ④ Sigla di identificazione revisione disegno
Revision number
- ⑤ Numero di identificazione figura stampo
Mould Cavity identification
- ⑥ Sigla data di fabbricazione
Manufacturing date

CAVITIES SUITABLE FOR 0.64 DUO TWIN MALE CONTACT:
P/N 60181031; 60181011

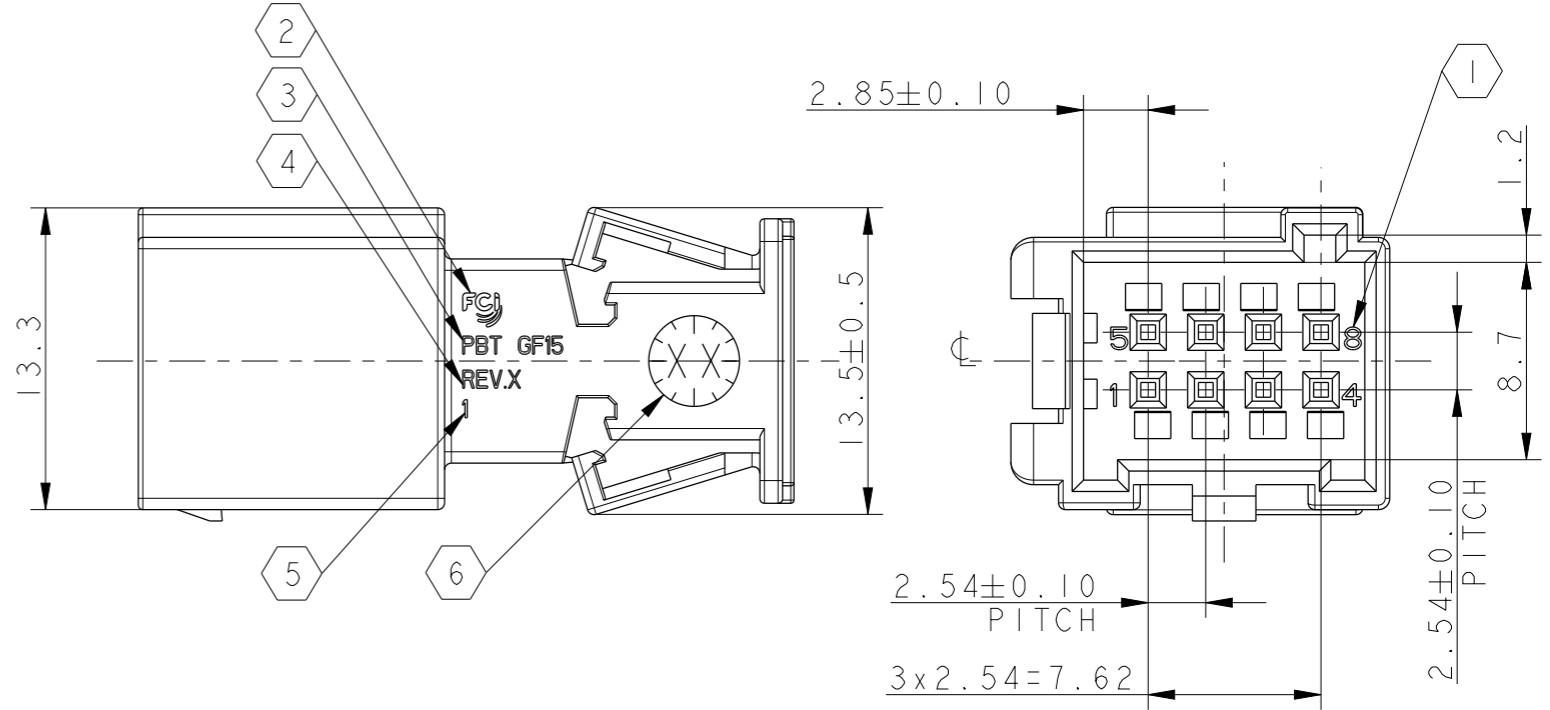
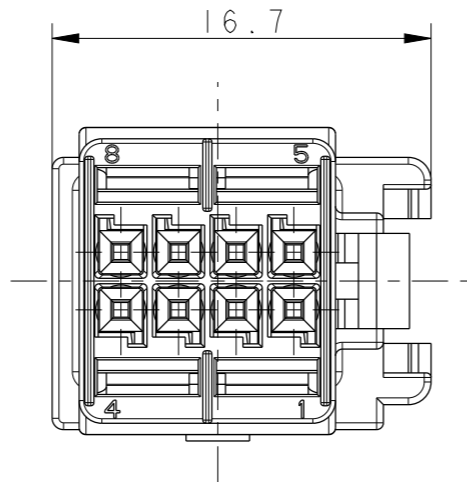

TPA CLOSED
SCALE 2:1

3D VIEW

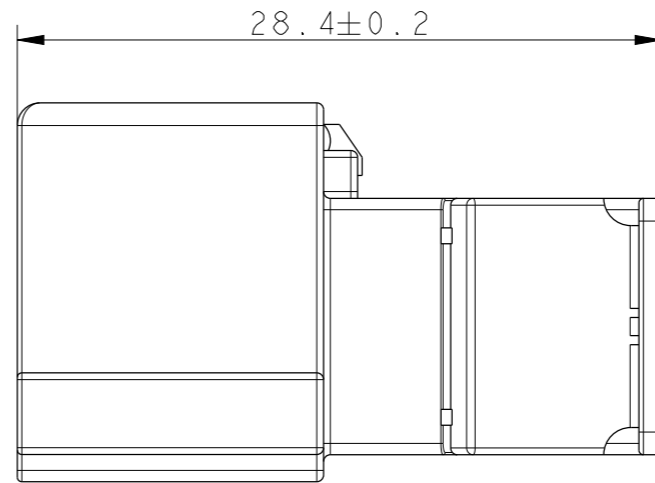
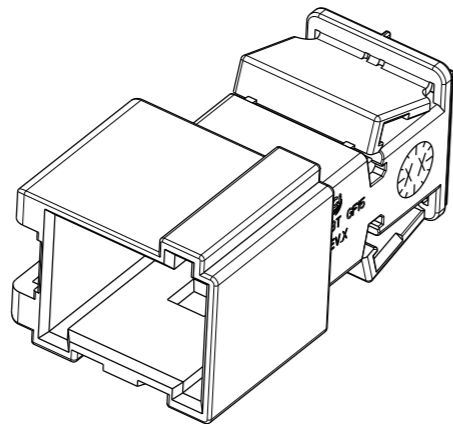
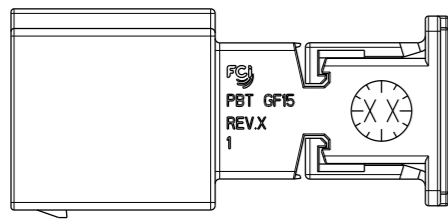

CODING TABLE

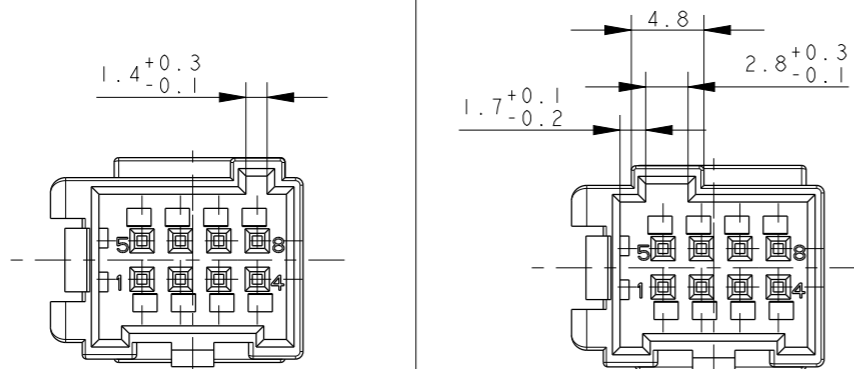

CODING

A

B

COLOUR

BLACK

GREY

FCI PART NUMBER

F647410

F747410

REV.

B

B

15-12402	-	-	UPDATED PART REVISION AND FRAME TABLE
	-	-	MODIFIED LOCKING FEATURES FOR CLIP ASSY (SEE ECN 15-12342)
	-	-	INITIAL RELEASE (SEE ECN 12-00870)

ECN-NO. NUMERO -ECH	POSITION POSIZIONE	CHANGE DESCRIPTION DESCRIZIONE MODIFICA	
PRODUCT SPEC. SPEC. DI PRODOTTO	PACKAGING SPEC. SPEC. DI IMBALLAGGIO	APPLICATION SPEC. SPEC. DI APPLICAZIONE	COPYRIGHT DELPHI CORPORATION AND/OR ITS AFFILIATES. ALL RIGHTS RESERVED. REVISED THIS DRAWING IS THE PROPERTY OF DELPHI CORPORATION AND CONTAINS DELPHI CONFIDENTIAL INFORMATION. THE REPRODUCTION, DISTRIBUTION AND UTILIZATION OF THIS DOCUMENT OR ITS RELATED CAD DATA, AS WELL AS COMMUNICATION OF ANY CONTENT TO OTHERS, WITHOUT EXPRESS AUTHORIZATION, IS PROHIBITED.
IP312	-	IP313	QUESTO DISEGNO E' PROPRIETA' DI DELPHI CORPORATION E CONTIENE INFORMAZIONI CONFIDENTIALI. LA RIPRODUZIONE, DISTRIBUZIONE E UTILIZZAZIONE DI QUESTO DOCUMENTO O DELLE SUE RELATIVE MATEMATICHE CAD, NONCHE LA COMUNICAZIONE DI QUALSIASI CONTENUTO AD ALTRI, SENZA ESPlicita AUTORIZZAZIONE, E' PROIBITA.
TOLERANCES TOLLERANZE	±0.3 / ±1°	MATERIAL : MATERIALE :	PBT 15GF
COUNTERPART Nr. CONTROPARTE Nr.	PP10000896 BLACK F947410 GREY	COLOUR : COLORE :	SEE TABLE
DO NOT MEASURE DRAWING DISEGNO FUORI SCALA	TOOL NO. STAMPO Nr.	ECO Loc. Code NAZIONALITA	IT
CREATED BY CREATO DA	DATE DATA	NAME NOME	TITLE DESCRIZIONE
2012/07/09		Davide TESTA	Male housing 8way 254x254
MODIFIED BY MODIFICATO DA	2015/03/18	Fausto GIRARD	PROJECT PROGETTO
CHECKED BY CONTROLLATO	2015/03/20	Davide TESTA	Family crimp
APPROVED BY APPROVATO	2015/03/20	M COLOMBO	ESR NO. NUMERO ESR
FILE NAME NOME FILE	PCC0790152	EU-120267	CAT. NO. NUMERO CAT.
		SEE TABLE	DOCUMENT UNDER PDS CONTROL DOCUMENTO GESTITO IN P.D.S.
			NO MODIFICATION ALLOWED OUTSIDE NESSUNA MODIFICA CONSENTITA FUORI SISTEMA

DELPHI
DELPHI PACKARD ELECTRICAL/ELECTRONIC ARCHITECTURE
TORINO, ITALY

C ISO PROJECTION
PROIEZIONE ISO

DIMENSION IN MILLIMETERS
DIMENSIONI IN MILLIMETRI

CAD SYSTEM
pro / eng.

DWG SIZE
FORMATO
A3

APPROVAL LEVEL
LIVELLO DI APPROVAZIONE

DRAWING NUMBER
NUMERO DISEGNO
PCC0790152

REV.
REV.
C

STATE
STATO
SERIAL RELEASED

PART NUMBER
NUMERO DI CATALOGO
See Table

REV.
REV.

SHEET
FOGLIO
1
of 1 di

SCALE
SCALA
3:1